

I6000/I6005 6-Axis Positioner User Manual

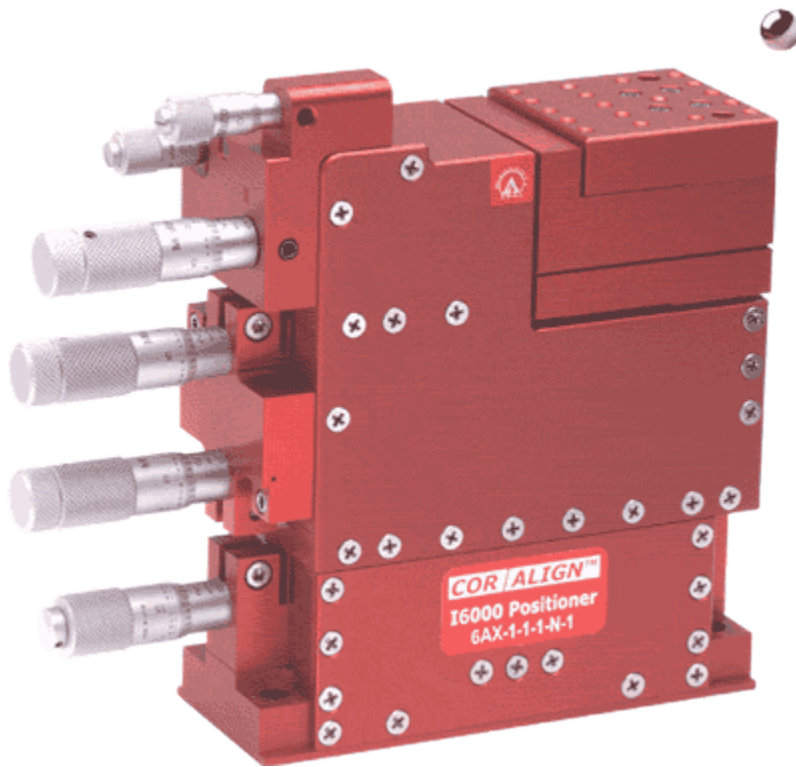

Table of Contents

Introduction to the I6000/I6005 Photonics Positioner	1
Feature Summary	2
Getting Started	3
Reading the Micrometers	3
Connecting an Automated Positioner	4
Actuator Driver	5
Mounting the Positioner.....	5
Mounting Devices and Accessories	5
Accessories	5
I6000/I6005 Specifications	7
What is Ratio Drive™?.....	8
25x Ratio Drive™.....	8
5x Ratio Drive™.....	8
Stepper Motor Actuators.....	9
Actuators with Built-In Controller (A and B Type).....	9
Included Software	9
Manual Control	9
Actuators Without a Controller (AM and BM Type)	9
Actuator Specifications.....	10
Available Options	11
Dimensional Drawings.....	13
Unpacking and Transportation.....	15
Locking Strip Removal.....	15
Contact Us.....	16
Mailing Address.....	16
Business Hours.....	16
Phone Contacts.....	16
Email Contacts	16
Warranty	17

Table of Figures

Figure 1 - Connecting an Automated Positioner (A and B type actuators)	4
Figure 2 - I6000/I6005 6-Axis Positioner.....	6
Figure 3 – Mini-din Actuator Connection	10
Figure 4 - I6000/I6005 Positioner (manual) Dimensions - Front & End.....	13
Figure 5 - I6000/I6005 Positioner (stepper motor) Dimensions - Top.....	13
Figure 6 - I6000/I6005 Positioner (manual) Dimensions - Top & Bottom	14
Figure 7 - I6000/I6005 Positioner (stepper motor) Dimensions - Front & End	14
Figure 8 – Unpacking.....	15

Introduction to the I6000/I6005 Photonics Positioner

Welcome to the I6000/I6005 Photonics Positioner - a positioning system so stable and easy to adjust that aligning single mode optical fibers is as easy as tuning a radio! There is no need to let go of the micrometers during operation; the I6000/I6005 is extremely touch insensitive. With the patented ergonomic inline design, all micrometers are easily accessible on one side. Just rest your hand comfortably on the table and enjoy the ease and efficiency of quickly aligning any type of fiber.

No fiber alignment challenge is too difficult - even 1-2 micron core lensed fibers can easily be aligned. The Luminos I6000/I6005 uses a patented Ratio Drive™ for the X & Y axes resulting in less hysteresis and increased resolution.

Conventional stacked stages have separate frames with each frame simply mounted on the output of the previous stage. This results in the stiffness at the micrometer being degraded by the lack of stiffness between the mounting reference and output of each stage below it. Hand forces on the micrometer are then easily transmitted directly to the output causing the alignment to wander; thus typically resulting in an adjust-release-wait cycle by the operator.

In contrast, the I6000/I6005 consists of only two frames. The Z stage is one frame while all the other micrometers are anchored to a shared fixed frame that is attached directly to the output of the Z stage. The Z stage is exceptionally stiff and therefore is not a factor. By sharing a common rigid frame, forces exerted on the micrometers by the operator during adjustment are shunted directly to the base instead of to the output. The operator can then quickly align without letting go.

The I6000/I6005 is also vibration and temperature insensitive. Internal viscous damping eliminates many of the resonance effects typically associated with flexure stages.

Luminos stages generate extremely smooth linear motion utilizing patented flexure technology. The error motion associated with frictional ball bearings has been eliminated. Consequently, these stages move with smooth monotonic motion. The force required from an actuator in order to move a stage is also linear without the typical stiction that is found with ball or frictional type stages.

In general, single stage flexure designs are subject to arcuate motional error as each single stage moves in a physical arc. In the Luminos design, the large travel Z stage is a frictionless dual compensated flexure design wherein two precision flexure stages are made to move identically together such that the arcuate errors are eliminated. This technique offers a straightness of motion that is comparable to a precision bearing stage while affording a large travel not commonly found in flexure designs. The flexure stages used for transverse ("X") and vertical ("Y") motion are single stage flexures; however, they are oriented such that their resultant arcuate motions are in the large travel "Z" direction (typically the optical axis). The overall result is that the Luminos stages can be operated in even a manual mode without the operator experiencing objectionable off-axis motion.

The rotational stages are also flexure based with frictionless drive systems. All the rotational axis are coincident and pass through a focal point that is located 1” in front of the stage and ½ inch above the work plate. This allows for up to 4 – 6 Axis stages to be arranged in a cluster around a small sample if desired. The Pitch and Yaw flexure stages have been carefully designed as “dual compensated flexure stages” identical in concept to the Z Axis stage. This allows a operator to pivot in virtual space without any significant off-axis arc error motion. Believe it or not, two aligned tapered optical single mode fibers with a mode field diameter of even 2 microns can be rotated throughout pitch and yaw while maintaining the optical signal. The roll stage is a frictionless drive single stage design. In a typical alignment of a fiber array, the bulk of any Roll adjustment is carried out in a far-field alignment state in order to align the fibers at either end of a fiber array. Subsequent fine rotational adjustments are then very minor and off-axis error motion is negligible. Tests have shown that SM fiber arrays up to 100 fibers wide (0.25mm spacing) can be aligned readily using a manual I6000. The precision and ease of use of this stage truly cannot be appreciated without having used it. In most cases, the I6000 enables difficult array elements to be easily aligned where the only previous option was to use an automated system. Luminos also offers full automation solutions based on the I6000 positioning platform that are truly unique. A complete automated solution including controllers can be held in your hand.

Feature Summary

- Patented Inline actuators provide ease of access and multiple unit workstations.
- Patented Ratio Drive™ system affords superior resolution for far less cost.
- Small footprint allows multiple unit workstations (Fig 2).
- Onboard controller for actuators avoids high cost of separate motion controllers.
- Damped exterior shell design provides superior vibration and touch insensitivity.
- Lightweight aluminum construction allows system to be moved easily by other motion equipment.
- High mechanical stiffness affords rugged and stable base system.
- Patented linear dual flexure Z offers frictionless repeatable straight travel.
- Dual flexure Yaw and Pitch stages provide extreme resolution without arc error.

With positioning this easy... the possibilities are endless.

Getting Started

Before unpacking the positioner, please read Unpacking and Transportation on page 15.

Reading the Micrometers

The following table gives the conversion necessary to interpret the numbers read from the micrometer.

Axis	Smallest Division (A)		1 Rotation (B)	
Pitch	30	arc seconds	15	arc minutes
Yaw	30	arc seconds	15	arc minutes
Roll	10	arc seconds	10	arc minutes
Y	1	µm	25	µm
X	1	µm	25	µm
Z	0.001	inches	0.025	inches

Each line on the shaft of the micrometer corresponds to one rotation. The “smallest division” refers to the divisions on the knob of the micrometer. Clockwise rotation of each micrometer causes movement in a positive direction as shown in Figure 2 (pg. 6).

To calculate the position, count the number of divisions on the shaft between the current position and zero. Multiply that number by the movement per rotation (B) given in the table above. Then, count the number divisions on the knob from zero, multiply that number by the movement per smallest division (A in the table above). Add the two products calculated to give the position. The formula is summarized as:

$$\text{Position} = (\text{Shaft_Divisions} \times B) + (\text{Knob_Divisions} \times A)$$

Note: If the coarse adjustment of the X or Y axis is moved, the position read from the micrometer of that axis will not be the same physical position as before moving the coarse adjustment.

Connecting an Automated Positioner

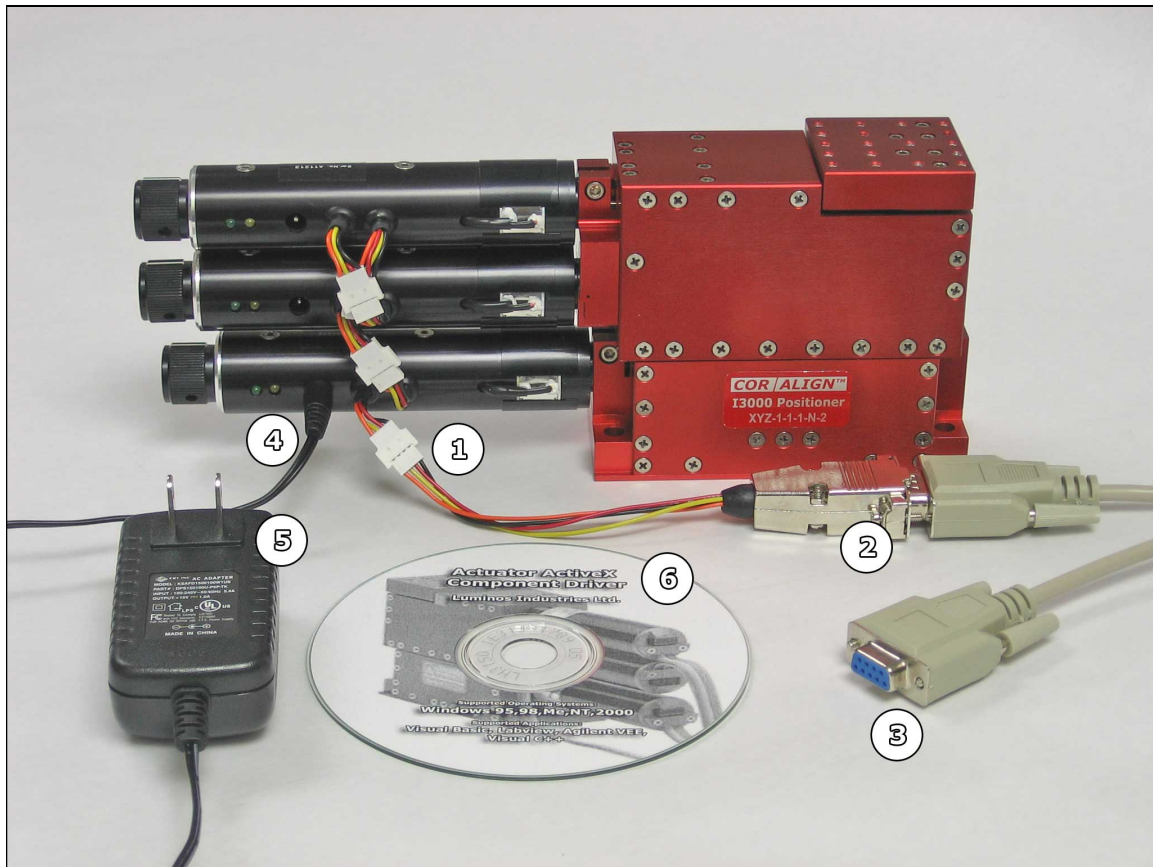

Figure 1 - Connecting an Automated Positioner (A and B type actuators)

To connect your positioner, use the following steps:

1. Connect the 9-pin adapter with the matching white connector to white connector on the bottom actuator closest to the manual knob. On any positioner with more than one axis, this will be the only white connector available on the bottom actuator. (Do not disconnect actuators that are already connected).
2. Connect the other end of the adapter (a female DB9 9 pin connector) to the 9-pin serial extension cable.
3. The end of the cable is a standard 9-pin female serial connection and should connect to one of the serial ports on the back of the computer (or to a Serial-USB adapter to utilize a USB port instead).
4. Connect the 12-16V DC (minimum 800mA) power adapter to the bottom actuator. The rest of the actuators are power through the daisy chain.
5. Plug the power adapter into a standard receptacle.
6. Install the software driver using the CD provided. Help for using the driver is included as part of the installation.

Actuator Driver

The documentation for actuator driver is included in the accompanying Driver CD (if applicable). This format allows easy access from within most software development environments.

Mounting the Positioner

The I6000/I6005 mounts using ¼-20 screws on 1 inch and 4 inch centers (see Figure 6 - I6000/I6005 Positioner (manual) Dimensions - Top & Bottom, pg 14)

Mounting Devices and Accessories

The device mounting plate (the square plate at the top of the positioner) is where devices and accessories are mounted. For dimensions, see Figure 6 on page 14. As shown in Figure 2 (pg. 6), the center of rotation for all axes is 1 inch out and ½ inch up from the end of the device mounting plate. To avoid having to adjust the X,Y and Z axes when rotating the device, the device alignment point should be as close as possible to the rotation center.

Accessories

There are many accessories available including a contact sensing system for sensing very small forces in the Z (focal) direction. Contact us if there is an accessory you require.

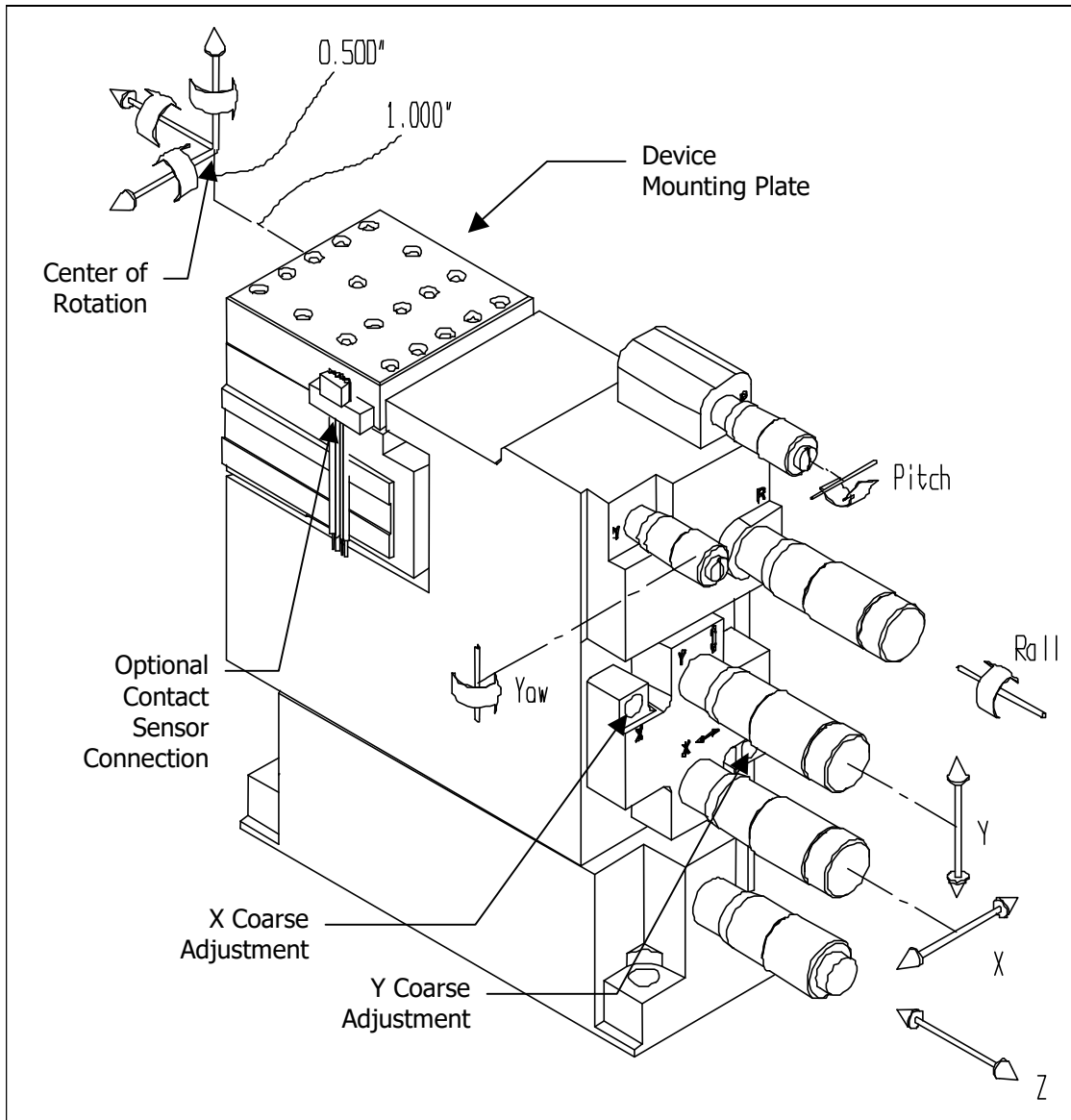

Figure 2 - I6000/I6005 6-Axis Positioner

I6000/I6005 Specifications

Travel				
<i>Axis</i>		<i>Actuator¹</i>	<i>Coarse</i>	<i>Total</i>
Z – focus		12.7mm (0.5")	N/A	12.7mm (0.500")
I6000	Y – vertical	0.5mm (0.02")	2mm (0.080")	2.5mm (0.1")
	X – lateral	0.5mm (0.02")	2mm (0.080")	2.5mm (0.1")
I6005	Y – vertical	2.5mm (0.1")	N/A	2.5mm (0.1")
	X – lateral	2.5mm (0.1")	N/A	2.5mm (0.1")
Roll		3 degrees	N/A	3 degrees
Yaw		3 degrees	N/A	3 degrees
Pitch		3 degrees	N/A	3 degrees
Setability ² (Micrometer)				
<i>Axis</i>		<i>Resolution</i>	<i>Movement /Division</i>	
Z		0.25 micron (10μ-inch)	0.001"	
I6000	Y	10nm (0.4μ-inch)	1μm - 25x Ratio Drive™	
	X	10nm (0.4μ-inch)	1μm - 25x Ratio Drive™	
I6005	Y	50nm (2μ-inch)	5μm - 5x Ratio Drive™	
	X	50nm (2μ-inch)	5μm - 5x Ratio Drive™	
Roll		0.1 arc sec	10 arc sec	
Yaw		0.2 arc sec	30 arc sec	
Pitch		0.2 arc sec	30 arc sec	
Resolution (Stepper Motor – Type A)				
<i>Axis</i>		<i>Resolution</i>	<i>Total Steps</i>	
Z		100nm (4μ-inch)	128 000	
I6000	Y	4nm (0.16μ-inch)	128 000 - 25x Ratio Drive™	
	X	4nm (0.16μ-inch)	128 000 - 25x Ratio Drive™	
I6005	Y	20nm (0.8μ-inch)	128 000 - 5x Ratio Drive™	
	X	20nm (0.8μ-inch)	128 000 - 5x Ratio Drive™	
Roll		0.1 arc sec	101 206	
Yaw		0.2 arc sec	60 416	
Pitch		0.2 arc sec	60 416	
Stage Configuration & Arc Error Motion				
<i>Axis</i>		<i>Flexure Type</i>	<i>Arc Error</i>	
Z		Dual	None - True Linear Motion	
Y		Single	Max 30μm - Arc Error in Z only	
X		Single	Max 30μm - Arc Error in Z only	
Roll		Single	Max 35μm	
Yaw		Dual	None	
Pitch		Dual	None	
Linear Stiffness				
<i>Along Axis</i>		<i>Stiffness</i>	<i>Comments</i>	
Z		130 kN/m	measured at the rotation center	
Y		95 kN/m	measured at the rotation center	
X		40 kN/m	measured at the rotation center	

Torsional Stiffness		
<i>About Axis</i>	<i>Stiffness</i>	<i>Comments</i>
Z – roll	75Nm/rad	measured at the rotation center
Y – yaw	100Nm/rad	measured at the rotation center
X – pitch	130Nm/rad	measured at the rotation center
Maximum Load		
<i>Static Load</i>	<i>Transient Load</i>	<i>Comments</i>
2.2 lbs (1kg)	10 lbs (4.5kg)	stage must be protected from shock loading during transport and usage
Physical Properties		
<i>Characteristic</i>	<i>Specifications</i>	<i>Comments</i>
Construction	Aluminum	6061 & 7075 - T6 anodized
Weight	1.5kg	Approximate
Body Dimensions	5.79" x 1.75" x 5.19"	LxWxH excluding micrometers
Mounting Height	5.19"	Base to top of mounting plate
Mounting Config. Imperial	0.26" dia. holes	1.00" x 4.00" ³ centers
Mounting Config. Metric	6.6mm dia. holes	25mm x 100mm centers
Concurrent Rotation Center	1/2"	Above top of mounting plate
	1"	Out from end of mounting plate

¹ 'Actuator' refers to a micrometer or stepper motor.

² Operator dependent

³ Compatible with 1.00" grid optical tables, units mount on 2" intervals with 0.25" allowance for routing of cables etc.

What is Ratio Drive™?

Ratio Drive™ is a means of "dividing down" the motion of the actuator to give higher resolution at the output of a positioner stage. This causes the output of the positioner stage to be only a fraction of the movement of the actuator - increasing resolution and decreasing backlash (since no gears are used in the Ratio Drive™). This technique allows the use of a standard micrometer or inexpensive stepper motor for enhanced, high precision alignment. Note: Ratio Drives™ are only on the X and Y axes.

25x Ratio Drive™

With the 25x Ratio Drive™, 12.7mm of micrometer travel is divided down 25.4 times to give 0.5mm of travel at the output plate. Coarse adjustments using an Allen key add an additional 2mm for a total of 2.5mm of travel. With the stepper motor actuator, the X & Y stages achieve a resolution of 4 nanometers on X and Y axes.

Products that incorporate the 25x Ratio Drive™ include the I3000, I5000 and I6000.

5x Ratio Drive™

A 5x Ratio Drive™ divides the motion down by 5 times so that one 12.7mm of actuator travel becomes 2.5mm at the output. With this option, there are no coarse adjustments

and the full 2.5mm of travel is available from the micrometer or stepper motor. With the stepper motor actuator, the X & Y stages achieve 20 nanometers of resolution.

Products that incorporate the 5x Ratio Drive™ include the I3005, I5005 and I6005.

Stepper Motor Actuators

Actuators with Built-In Controller (A and B Type)

The A and B type actuators do not require an external stepper motor driver - these slim actuators actually contain an onboard RS-232 controller which interfaces directly with any standard PC serial port (or USB port with a low cost adapter). Each Positioner is shipped with a 15 Volt, 1 Amp DC Voltage adapter, a 4-pin Molex to 9-pin serial adapter, and a 2m 9-pin extension.

Included Software

An included ActiveX/COM™ software component makes it easy to get up and running quickly in any windows based development environment (including Visual Basic, Labview, and C++, or any of the .NET languages).

Manual Control

A convenient knob at the end of the unit permits manual control. During a manual move the actuator constantly updates the connected computer with its position. If accidental movement is a concern, the manual control can be enabled and disabled via computer control.

Actuators Without a Controller (AM and BM Type)

The AM and BM type actuators are equivalent to the A and B type actuators without controllers. They are provided with direct connections to the two phases of the bipolar stepper motor (4 wires) and a Hall Effect limit sensor (3 wires) through a male 8-pin mini-din connector.

This option allows those with an existing system for driving stepper motors to avoid changing over to RS-232 based control. However, for new applications, this option is not recommended due to the high cost of separate controllers.

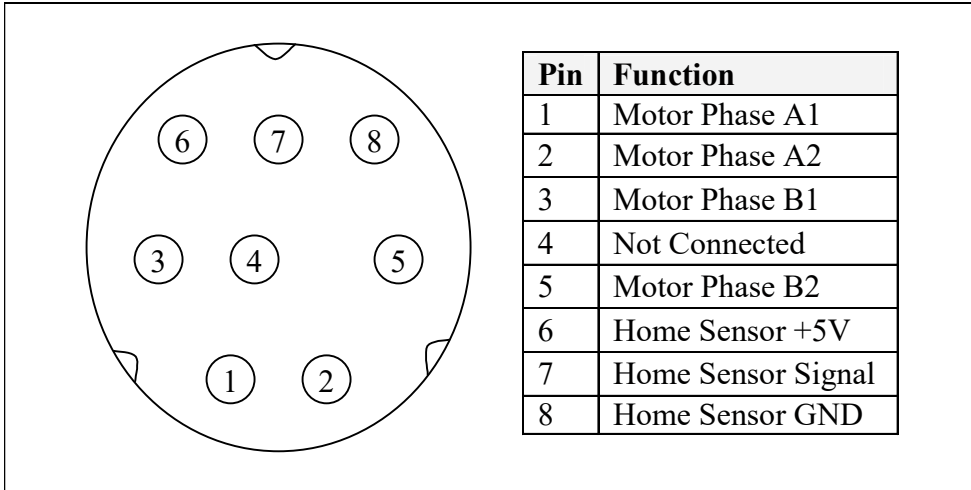

Figure 3 – Mini-din Actuator Connection

Actuator Specifications

Description	Actuator Type			
	A	AM	B	BM
Motor Type	Bipolar Stepper			
Built-in Controller	Yes	No	Yes	No
Steps Per Revolution	48			
Motion Per Step	6.35 μm		12.7 μm	
Power Per Phase	1.7W			
Resistance Per Phase	84 ohms		14.7 ohms	
Current per Phase	140 mA		340 mA	
Inductance per Phase	55 mH		8.5 mH	
Accuracy	< 12 μm		< 16 μm	
Backlash	< 4 μm		< 8 μm	
Repeatability	< 0.4 μm		< 0.8 μm	
Power Supply	12V-16V DC unregulated 2.1mm center positive plug (A and B type only)			
Current Draw	Idle: 100 mA Moving: 320 mA			

Table 1 - Actuator Specifications

Note that the accuracy, backlash, repeatability and resolution are improved considerably on the X and Y axes by the 5x Ratio Drive and more so by the 25x Ratio Drive.

Available Options

Z Actuator

Manual Imperial Micrometer (default)

*A micrometer where the smallest division is 0.001 inches
(0.025" per revolution)*

Differential Micrometer (Imperial)

*A double threaded micrometer for increased resolution where the smallest
division is 0.00002 inches.*

Stepper, Fine Travel, 0.1 μ m microstep, RS-232 Onboard Controller

Stepper, Long Life, 0.2 μ m microstep, RS-232 Onboard Controller

Stepper, Fine Travel, 6.4 μ m fullstep, Direct Mini-DIN 8

Stepper, Long Life, 12.8 μ m fullstep, Direct Mini-DIN 8

X Actuator

Manual Imperial Micrometer (default)

A micrometer where the smallest division is 1 μ m (25 μ m per revolution)

Stepper, Fine Travel, 0.1 μ m microstep, RS-232 Onboard Controller

Stepper, Long Life, 0.2 μ m microstep, RS-232 Onboard Controller

Stepper, Fine Travel, 6.4 μ m fullstep, Direct Mini-DIN 8

Stepper, Long Life, 12.8 μ m fullstep, Direct Mini-DIN 8

Y Actuator

Manual Imperial Micrometer (default)

A micrometer where the smallest division is 1 μ m (25 μ m per revolution)

Stepper, Fine Travel, 0.1 μ m microstep, RS-232 Onboard Controller

Stepper, Long Life, 0.2 μ m microstep, RS-232 Onboard Controller

Stepper, Fine Travel, 6.4 μ m fullstep, Direct Mini-DIN 8

Stepper, Long Life, 12.8 μ m fullstep, Direct Mini-DIN 8

Roll Actuator

Manual Micrometer (default)

*A micrometer where the smallest division is 10 arc sec
(10 arc min per revolution)*

Stepper, Fine Travel, 0.1 μ m microstep, RS-232 Onboard Controller

Stepper, Long Life, 0.2 μ m microstep, RS-232 Onboard Controller

Stepper, Fine Travel, 6.4 μ m fullstep, Direct Mini-DIN 8

Stepper, Long Life, 12.8 μ m fullstep, Direct Mini-DIN 8

Yaw Actuator

Manual Micrometer (default)

*A micrometer where the smallest division is 30 arc sec
(15 arc min per revolution)*

Stepper, Fine Travel, 0.1 μ m microstep, RS-232 Onboard Controller

Stepper, Long Life, 0.2 μ m microstep, RS-232 Onboard Controller

Stepper, Fine Travel, 6.4 μ m fullstep, Direct Mini-DIN 8

Stepper, Long Life, 12.8 μ m fullstep, Direct Mini-DIN 8

Pitch Actuator

Manual Micrometer (default)

*A micrometer where the smallest division is 30 arc sec
(15 arc min per revolution)*

Stepper, Fine Travel, 0.1 μ m microstep, RS-232 Onboard Controller

Stepper, Long Life, 0.2 μ m microstep, RS-232 Onboard Controller

Stepper, Fine Travel, 6.4 μ m fullstep, Direct Mini-DIN 8

Stepper, Long Life, 12.8 μ m fullstep, Direct Mini-DIN 8

XY Coarse Adjust

40 pitch set screw (default)

A flush set screw that gives 1/40 inches per revolution. Requires 3/32" ball point hex driver, McMaster-Carr Catalogue # 7268A54

40 pitch thumbscrew

A small knob that gives 1/40 inches per revolution at the output; allows easy adjustment of the coarse control.

80 pitch thumbscrew

A small knob that gives 1/80 inches per rotation at the output; allows easy adjustment of the coarse control.

Mounting Axis

Horizontal (default)

The positioner is set up to be balanced in the horizontal and upright position.

Vertical

The positioner is set up to be balanced with the micrometers pointing up. This configuration requires more preload on the z-axis.

Units

Imperial (Default)

1" table: 1/4-20, 4-40 device mounting plate

SI

25mm table: M6, M2.5x0.7mm device mounting plate

Note: Imperial and SI units are dimensionally the same.

Dimensional Drawings

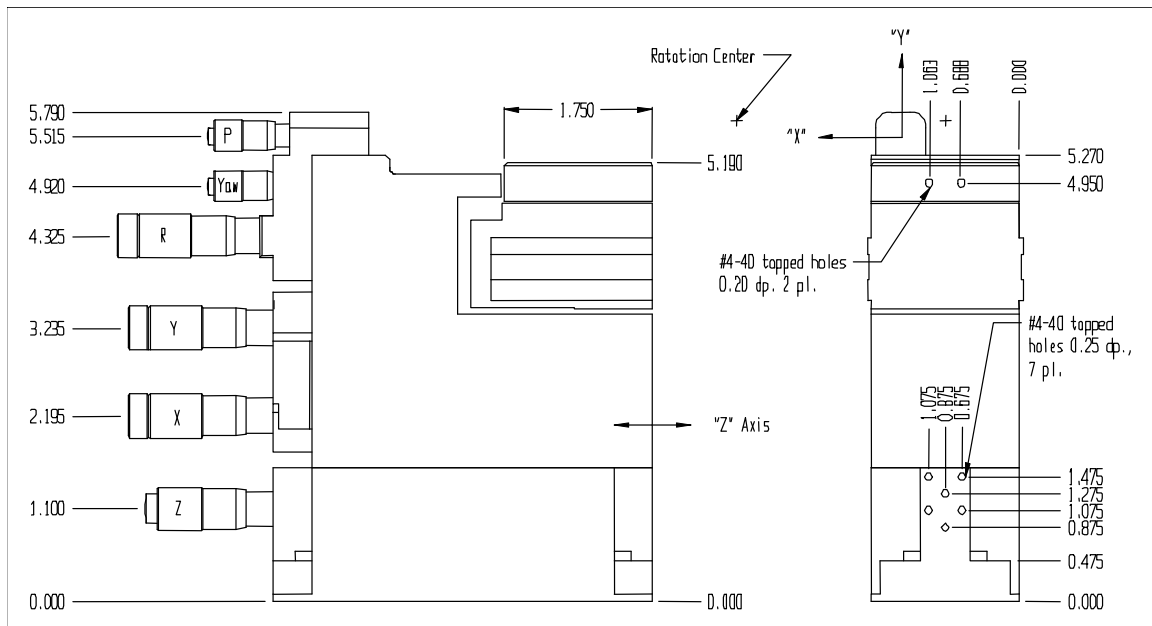

Figure 4 - I6000/I6005 Positioner (manual) Dimensions - Front & End

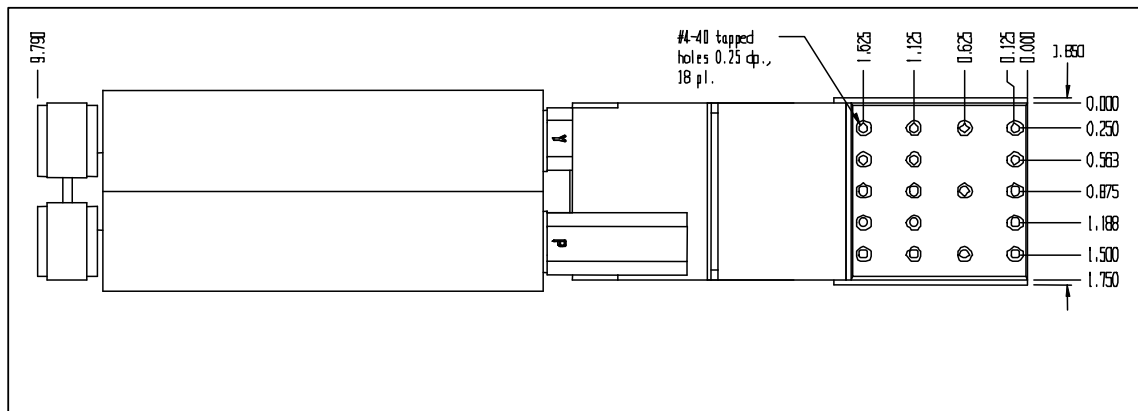

Figure 5 - I6000/I6005 Positioner (stepper motor) Dimensions - Top

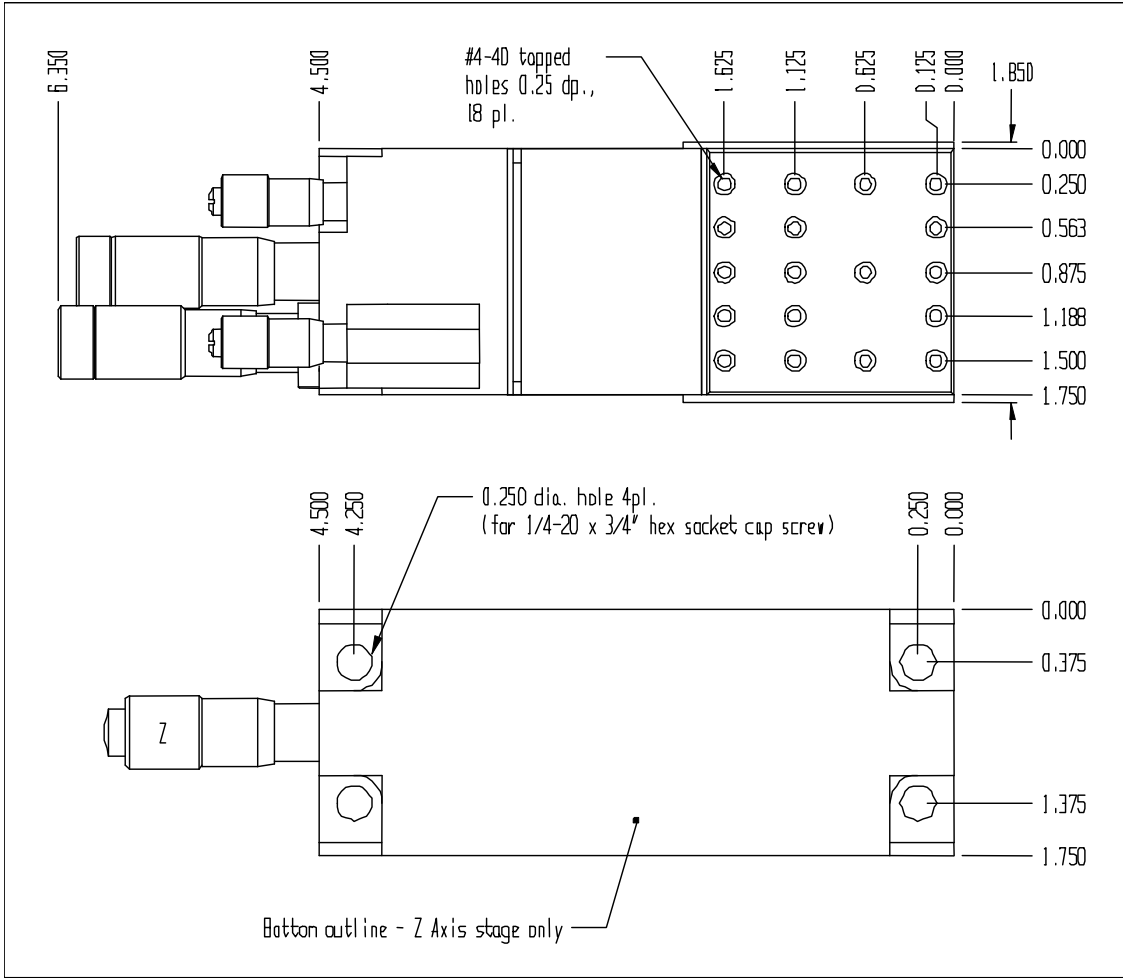

Figure 6 - I6000/I6005 Positioner (manual) Dimensions - Top & Bottom

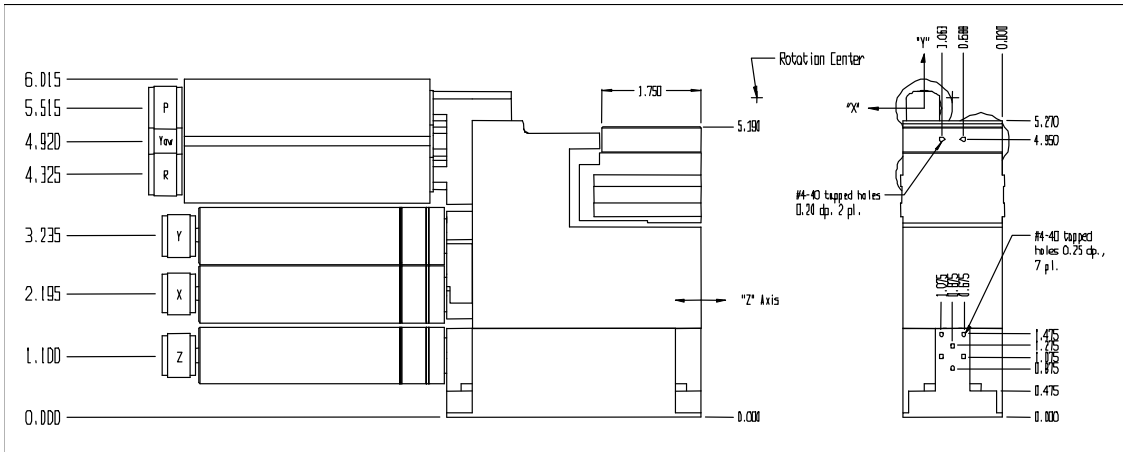

Figure 7 - I6000/I6005 Positioner (stepper motor) Dimensions - Front & End

Unpacking and Transportation

Do not discard packaging! The warranty is void if a Positioner is not shipped in the original packaging.

Locking Strip Removal

To prevent damage to the Z axis linkage during transportation a plastic locking strip is inserted between the upper and lower part of the unit (see Figure 8, below). To remove the locking strip, apply hand force to the upper portion of the unit (Z axis direction), remove locking strip and carefully allow the unit to return to its pre-loaded position. This procedure is applicable to all positioner types.

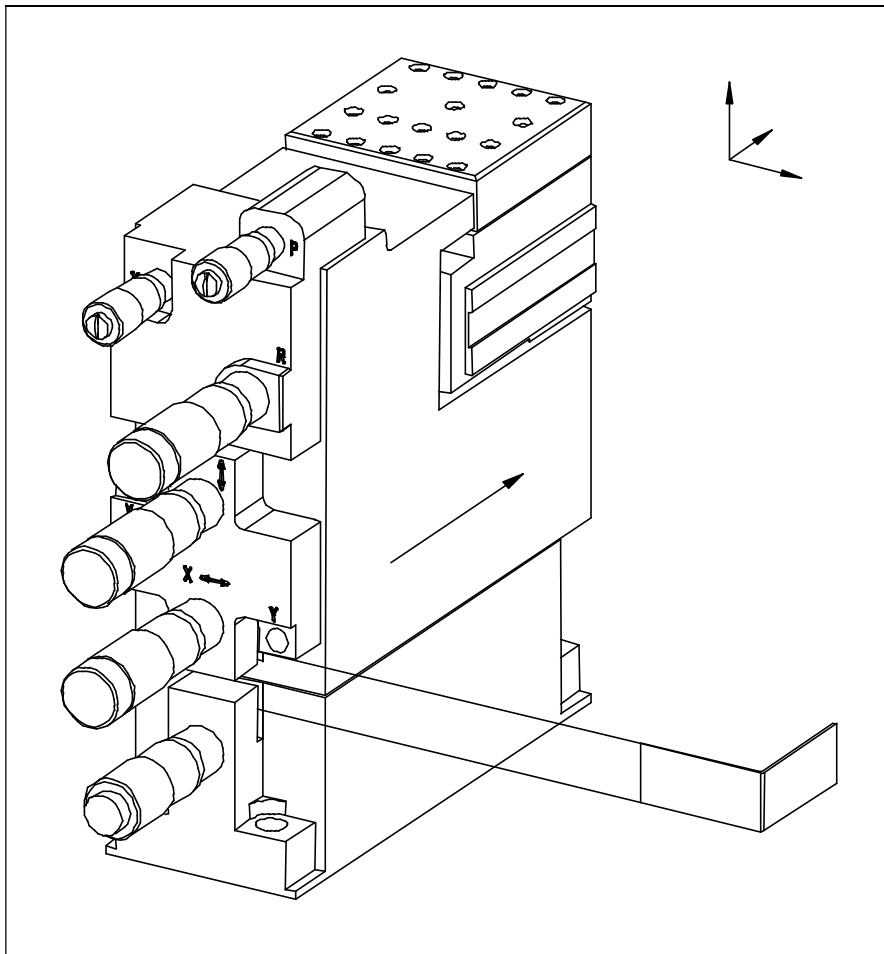

Figure 8 – Unpacking

Contact Us

Thank you for purchasing a Luminos product. We want to ensure your experience is a positive one. If you have any questions, concerns, or comments do not hesitate to contact us.

Mailing Address

Luminos Photonics
100-159 Cleopatra Drive
Ottawa, Ontario
K2G 5X4 - Canada

Business Hours

Monday to Friday: 9:00am-4:30pm EST

Phone Contacts

Telephone: 1 (613) 225-7661
Fax: 1 (613) 225-3391

Email Contacts

Sales: sales@luminos.com
General Inquiry: info@luminos.com
Support: support@luminos.com

Warranty

All items manufactured by Luminos Photonics are warranted to meet Luminos Photonics published specifications and to be free of defects in materials and workmanship as defined in the specifications for 90 days after delivery. Luminos Photonics will, at its own option, repair or replace without charge any listed item discovered to be defective.

Luminos Photonics will not be held liable for any loss whatsoever beyond the purchase price paid by the buyer for the goods to which claim is made. Luminos Photonics does not give implied warranties of merchantability, fitness for a particular purpose, or of any other nature in connection with the sale of any Luminos Photonics products.

Products not returned in original packaging will void this warranty.

This warranty does not extend to cover damage resulting from alteration, misuse, negligence, abuse, normal wear and tear, or accident.

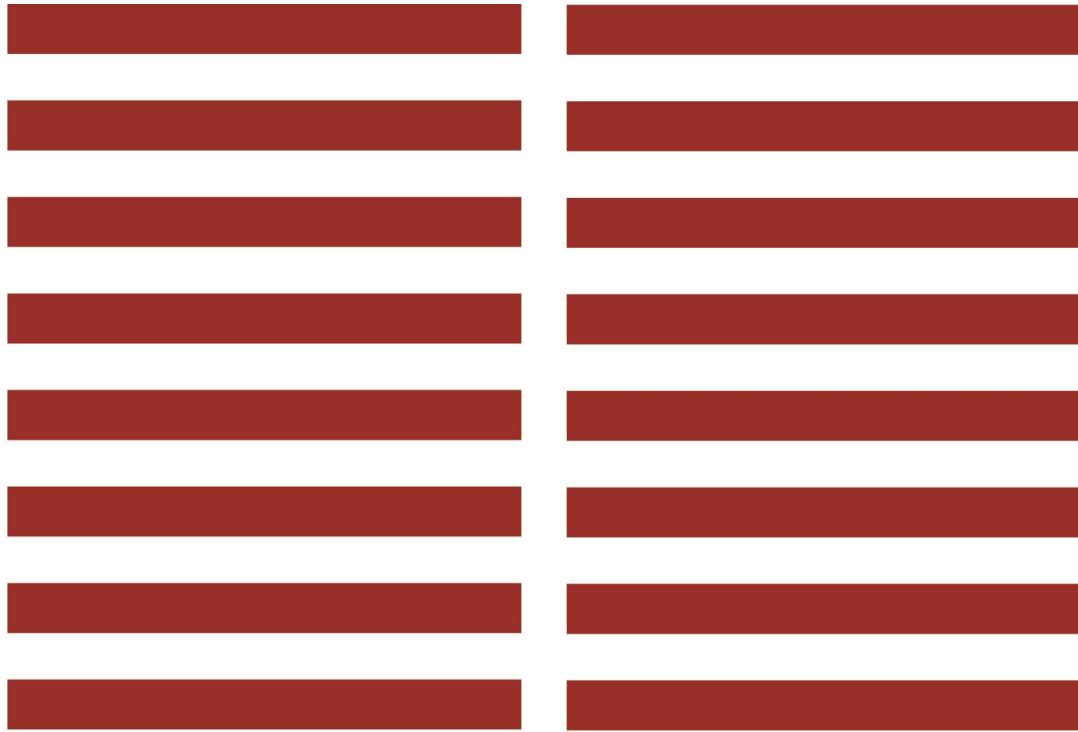

LUMINOS

P H O T O N I C S

**100 -159 Cleopatra Drive
Ottawa, Ontario
Canada
K2G 5X4**

**613 225 7661 – tel
613 225 3391 – fax**

**www.luminos.com
info@luminos.com**