

Rotational Positioner User Manual

Parts: P3R, P2YP, P2RY, P2RP

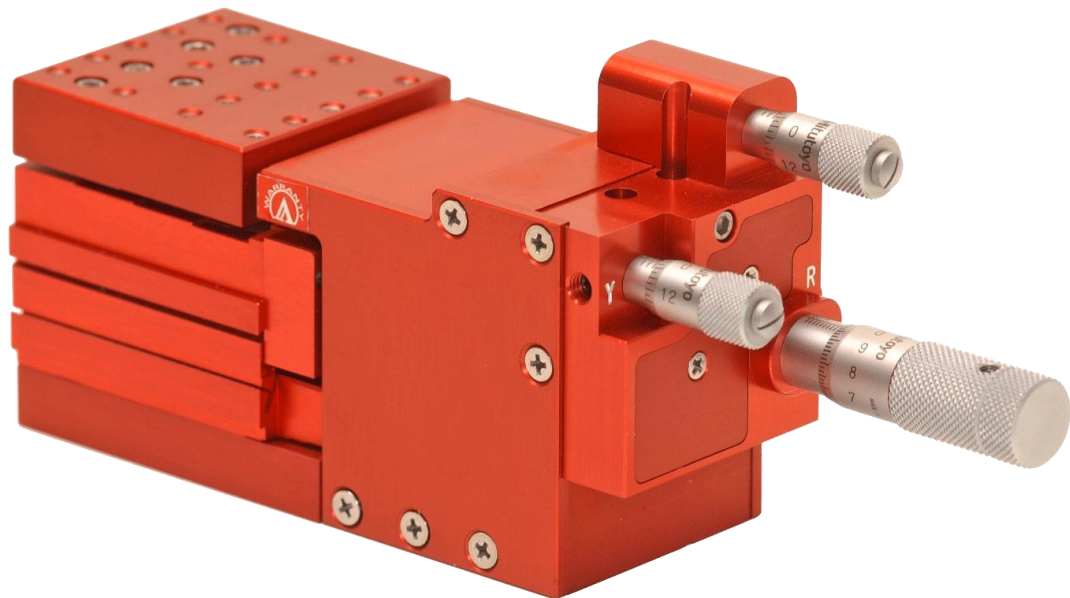

Table of Contents

Introduction to the Rotational Positioner	1
Feature Summary	2
Getting Started	3
Reading the Micrometers	3
Connecting an Automated Positioner	4
Actuator Driver	5
Mounting the Positioner.....	5
Mounting Devices and Accessories	5
Accessories	5
RYP3000 Specifications	6
Stepper Motor Actuators.....	7
Actuators with Built-In Controller (A and B Type).....	7
Included Software	7
Manual Control	7
Actuators Without a Controller (AM and BM Type)	7
Actuator Specifications	8
Available Options	9
Dimensional Drawings.....	10
Unpacking and Transportation.....	12
Warranty	13
Contact Us.....	14
Mailing Address.....	14
Business Hours.....	14
Phone Contacts.....	14
Email Contacts	14

Table of Figures

Figure 1 - Connecting an Automated Positioner (A and B type actuators)	4
Figure 2 – RYP3000 3-Axis Rotational Positioner.....	5
Figure 3 – Mini-din Actuator Connection	8
Figure 4 – RYP3000 Positioner (manual) Dimensions - Front & End	10
Figure 5 – RYP3000 Positioner (stepper motor) Dimensions - Top	10
Figure 6 – RYP3000 Positioner (manual) Dimensions - Top & Bottom.....	11
Figure 7 – RYP3000 Positioner (stepper motor) Dimensions - Front	11
Figure 8 – RYP3000 Positioner (stepper motor) Dimensions - End	12

Introduction to the Rotational Positioner

Welcome to the Luminos rotational positioner - a positioning system so stable and easy to adjust that angular alignment is as easy as tuning a radio! There is no need to let go of the micrometers during operation; the positioner is extremely touch insensitive. With the patented ergonomic inline design, all micrometers are easily accessible on one end. Just rest your hand comfortably on the table and enjoy the ease and efficiency of quick alignment.

Conventional stacked stages have separate frames with each frame simply mounted on the output of the previous stage. This results in the stiffness at the micrometer being degraded by the lack of stiffness between the mounting reference and output of each stage below it. Hand forces on the micrometer are then easily transmitted directly to the output causing the alignment to wander; thus typically resulting in an adjust-release-wait cycle by the operator.

In contrast, the Luminos rotational positioner consists of only one frame. By sharing a common rigid frame, forces exerted on the micrometers by the operator during adjustment are shunted directly to the base instead of to the output. The operator can then quickly align without letting go.

The positioner is also vibration and temperature insensitive. Internal viscous damping eliminates many of the resonance effects typically associated with flexure stages.

Luminos stages generate extremely smooth linear motion utilizing patented flexure technology. The error motion associated with frictional ball bearings has been eliminated. Consequently, these stages move with smooth monotonic motion. The force required from an actuator in order to move a stage is also linear without the typical stiction that is found with ball or frictional type stages.

All the rotational axes are coincident and pass through a focal point that is located 1" in front of the stage and ½ inch above the work plate. This allows for up to 4 – 6 Axis stages to be arranged in a cluster around a small sample if desired. The Pitch and Yaw flexure stages have been carefully designed as dual compensated flexure stages. This allows an operator to pivot in virtual space without any significant off-axis arc error motion. Believe it or not, two aligned tapered optical single mode fibers with a mode field diameter of even 2 microns can be rotated throughout pitch and yaw while maintaining the optical signal. The roll stage is a frictionless drive single stage design. In a typical alignment of a fiber array, the bulk of any Roll adjustment is carried out in a far-field alignment state in order to align the fibers at either end of a fiber array. Subsequent fine rotational adjustments are then very minor and off-axis error motion is negligible. Tests have shown that SM fiber arrays up to 100 fibers wide (0.25mm spacing) can be readily aligned using a manual rotational positioner. The precision and ease of use of this stage truly cannot be appreciated without having used it. In most cases, difficult array elements can be easily aligned manually where the only previous option was to use an automated system. Luminos also offers full automation solutions that are truly unique. A complete automated solution including controllers can be held in your hand.

Feature Summary

- Patented Inline actuators provide ease of access.
- Patent pending All-Flexure Drive™ system affords superior resolution for far less cost.
- Small footprint allows many degrees of freedom in a small space.
- Affordable, onboard stepper controllers provide a simple high-level RS-232 interface.
- Damped exterior shell design provides superior vibration and touch insensitivity.
- Lightweight aluminum construction allows system to be moved easily by other motion equipment.
- High mechanical stiffness affords rugged and stable base system.
- Dual flexure Yaw and Pitch stages provide extreme resolution without arc error.
- Can be used with 3-axis XYZ stage to provide a complete 6-axis system

With positioning this easy... the possibilities are endless.

Getting Started

Before unpacking the positioner, please read **Unpacking and Transportation** on page 12.

Reading the Micrometers

The following table gives the conversion necessary to interpret the numbers read from the micrometer.

Axis	Smallest Division (A)		1 Rotation (B)	
Pitch	30	arc seconds	15	arc minutes
Yaw	30	arc seconds	15	arc minutes
Roll	10	arc seconds	10	arc minutes

Each line on the shaft of the micrometer corresponds to one rotation. The “smallest division” refers to the divisions on the knob of the micrometer. Clockwise rotation of each micrometer causes movement in a positive direction as shown in Figure 2 (pg. 5).

To calculate the position, count the number of divisions on the shaft between the current position and zero. Multiply that number by the movement per rotation (B) given in the table above. Then, count the number divisions on the knob from zero; multiply that number by the movement per smallest division (A in the table above). Add the two products calculated to give the position. The formula is summarized as:

$$\text{Position} = (\text{Shaft_Divisions} \times B) + (\text{Knob_Divisions} \times A)$$

Connecting an Automated Positioner

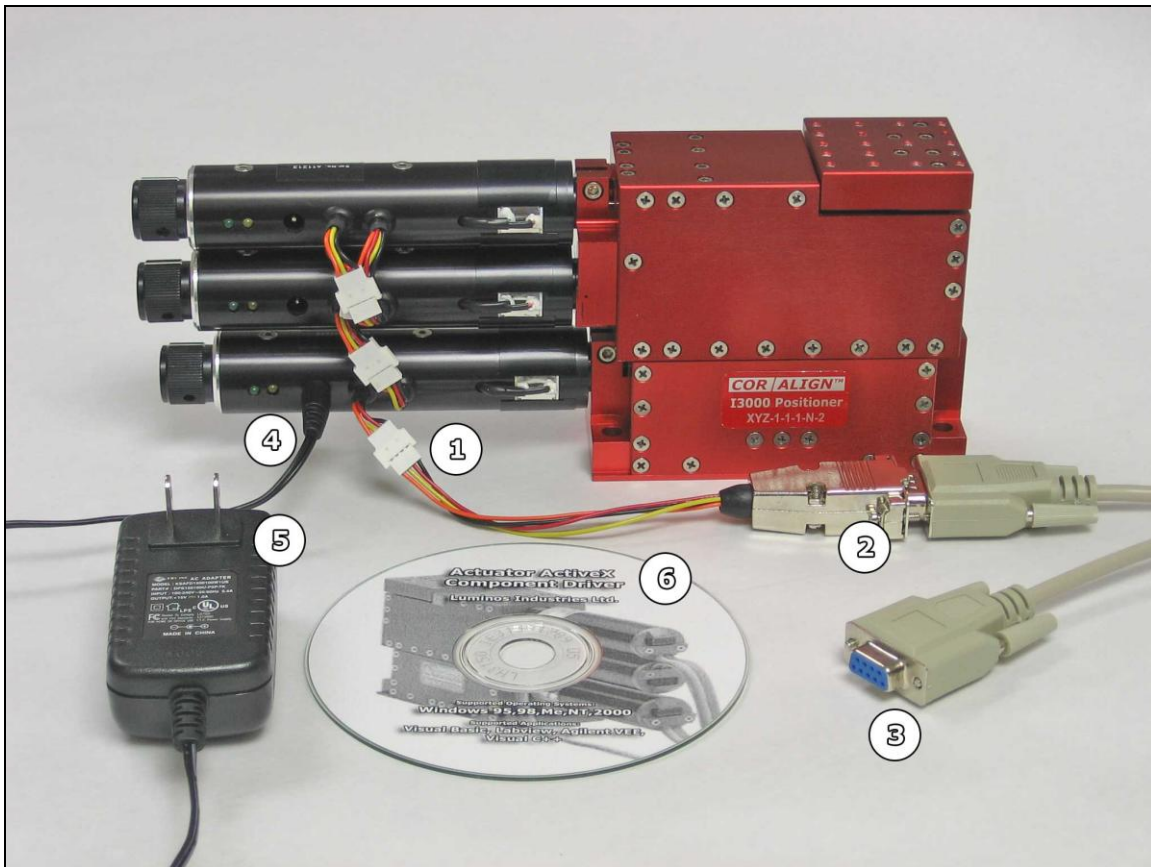

Figure 1 - Connecting an Automated Positioner (A and B type actuators)

To connect your positioner, use the following steps:

1. Connect the 9-pin adapter with the matching white connector to white connector on the bottom actuator closest to the manual knob. On any positioner with more than one axis, this will be the only white connector available on the bottom actuator. (Do not disconnect actuators that are already connected).
2. Connect the other end of the adapter (a female DB9 9 pin connector) to the 9-pin serial extension cable.
3. The end of the cable is a standard 9-pin female serial connection and should connect to one of the serial ports on the back of the computer (or to a Serial-USB adapter to utilize a USB port instead).
4. Connect the 12-16V DC (minimum 800mA) power adapter to the bottom actuator. The rest of the actuators are power through the daisy chain.
5. Plug the power adapter into a standard receptacle.
6. Install the software driver using the CD provided. Help for using the driver is included as part of the installation.

Actuator Driver

The documentation for actuator driver is included in the accompanying Driver CD (if applicable). This format allows easy access from within most software development environments.

Mounting the Positioner

Rotational Positioners are mounted using #6-32 screws as shown in Figure 6 (pg 11)

Mounting Devices and Accessories

The device mounting plate (the square plate at the top of the positioner) is where devices and accessories are mounted. For dimensions, see Figure 6 on page 11. As shown in Figure 2 (pg. 5), the center of rotation for all axes is 1 inch out and ½ inch up from the end of the device mounting plate

Accessories

There are many accessories available including a contact sensing system for sensing very small forces in the Z (focal) direction. Contact us if there is an accessory you require.

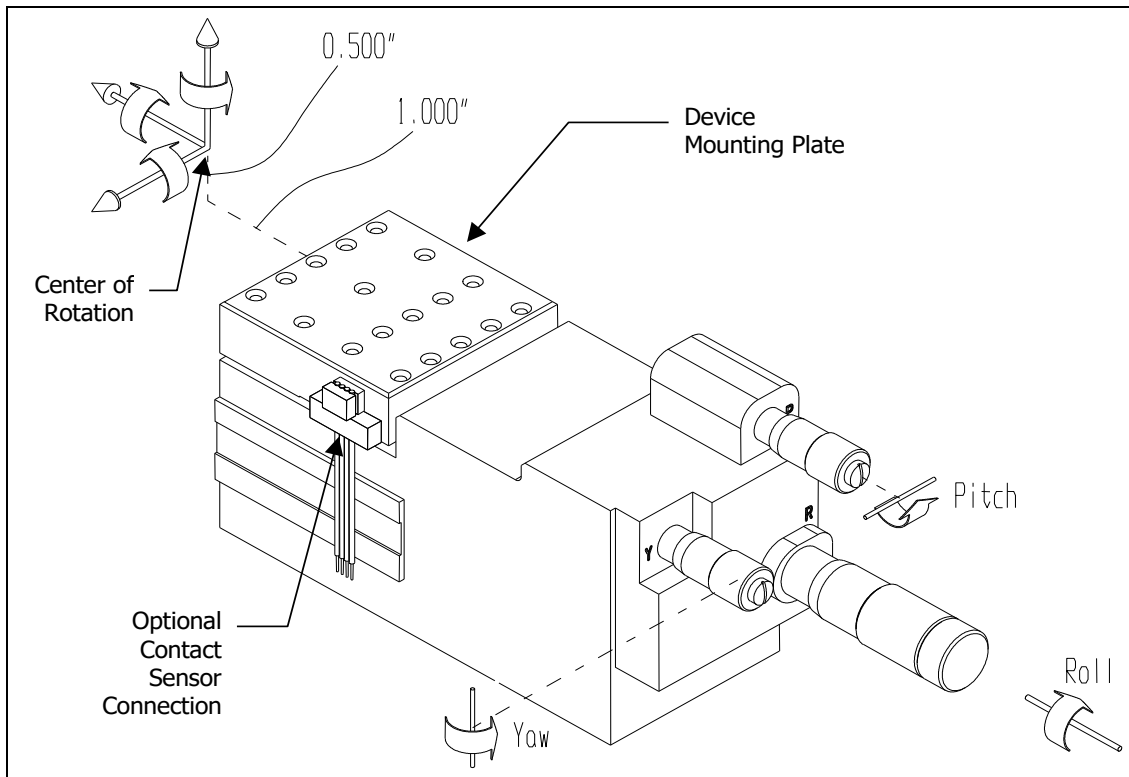

Figure 2 – RYP3000 3-Axis Rotational Positioner

RYP3000 Specifications

Travel			
<i>Axis</i>	<i>Actuator¹</i>	<i>Coarse</i>	<i>Total</i>
Roll	3 degrees	N/A	3 degrees
Yaw	3 degrees	N/A	3 degrees
Pitch	3 degrees	N/A	3 degrees
Setability ¹ (Micrometer)			
<i>Axis</i>	<i>Resolution</i>	<i>Movement /Division</i>	
Roll	0.2 arc sec	10 arc sec	
Yaw	0.4 arc sec	30 arc sec	
Pitch	0.4 arc sec	30 arc sec	
Resolution (Stepper Motor)			
<i>Axis</i>	<i>Resolution</i>	<i>Total Steps</i>	
Roll	0.1 arc sec	101 206	
Yaw	0.2 arc sec	60 416	
Pitch	0.2 arc sec	60 416	
Stage Configuration & Arc Error Motion			
<i>Axis</i>	<i>Flexure Type</i>	<i>Arc Error</i>	
Roll	Single	Max 35µm	
Yaw	Dual	None	
Pitch	Dual	None	
Linear Stiffness ²			
<i>Along Axis</i>	<i>Stiffness</i>	<i>Comments</i>	
Z	270 kN/m	measured at the rotation center	
Y	120 kN/m	measured at the rotation center	
X	60 kN/m	measured at the rotation center	
Torsional Stiffness ²			
<i>About Axis</i>	<i>Stiffness</i>	<i>Comments</i>	
Z – roll	80Nm/rad	measured at the rotation center	
Y – yaw	120Nm/rad	measured at the rotation center	
X – pitch	150Nm/rad	measured at the rotation center	
Maximum Load			
<i>Static Load</i>	<i>Transient Load</i>	<i>Comments</i>	
2.2 lbs (1kg)	10 lbs (4.5kg)	stage must be protected from shock loading during transport and usage	
Physical Properties			
<i>Characteristic</i>	<i>Specifications</i>	<i>Comments</i>	
Construction	Aluminum	6061 & 7075 - T6 anodized	
Weight	600g	Approximate	
Body Dimensions	4.50" x 1.75" x 2.70"	LxWxH excluding micrometers	
Mounting Height ³	2.10"	Base to top of mounting plate	
Mounting Config.	0.26" dia. holes	1.675" x 0.75" centers	
Concurrent Rotation Center	1/2"	Above top of mounting plate	
	1"	Out from end of mounting plate	

¹ Operator dependent

² Stiffness is nominally higher for RYP1000 (1 Axis) and RYP2000(2 Axis) stages

³ For optical table mount use with adaptor plate PT023805 add 0.30", for alignment compatibility with I3000 use spacer block PT023802. Other spacer plates and blocks available on request.

Stepper Motor Actuators

Actuators with Built-In Controller (A and B Type)

The A and B type actuators do not require an external stepper motor driver - these slim actuators actually contain an onboard RS-232 controller which interfaces directly with any standard PC serial port (or USB port with a low cost adapter). Each Positioner is shipped with a 15 Volt, 1 Amp DC Voltage adapter, a 4-pin Molex to 9-pin serial adapter, and a 2m 9-pin extension.

Included Software

An included ActiveX/COM™ software component makes it easy to get up and running quickly in any windows based development environment (including Visual Basic, Labview, and C++, or any of the .NET languages).

Manual Control

A convenient knob at the end of the unit permits manual control. During a manual move the actuator constantly updates the connected computer with its position. If accidental movement is a concern, the manual control can be enabled and disabled via computer control.

Actuators Without a Controller (AM and BM Type)

The AM and BM type actuators are equivalent to the A and B type actuators without controllers. They are provided with direct connections to the two phases of the bipolar stepper motor (4 wires) and a Hall Effect limit sensor (3 wires) through a male 8-pin mini-din connector.

This option allows those with an existing system for driving stepper motors to avoid changing over to RS-232 based control. However, for new applications, this option is not recommended due to the high cost of separate controllers.

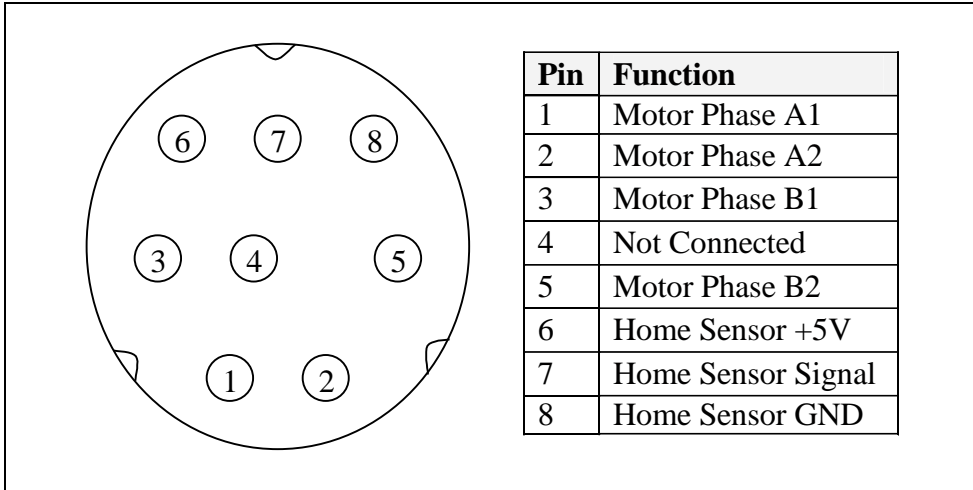

Figure 3 – Mini-din Actuator Connection

Actuator Specifications

Description	Actuator Type			
	A	AM	B	BM
Motor Type	Bipolar Stepper			
Built-in Controller	Yes	No	Yes	No
Steps Per Revolution	48			
Motion Per Step	6.35 μm		12.7 μm	
Power Per Phase	1.7W			
Resistance Per Phase	84 ohms		14.7 ohms	
Current per Phase	140 mA		340 mA	
Inductance per Phase	55 mH		8.5 mH	
Accuracy	< 12 μm		< 16 μm	
Backlash	< 4 μm		< 8 μm	
Repeatability	< 0.4 μm		< 0.8 μm	
Power Supply	12V-16V DC unregulated 2.1mm center positive plug (A and B type only)			
Current Draw	Idle: 100 mA Moving: 320 mA			

Table 1 - Actuator Specifications

Available Options

Roll Actuator

Manual Micrometer (default)

*A micrometer where the smallest division is 10 arc sec
(10 arc min per revolution)*

Stepper, Fine Travel, 0.1 μ m microstep, RS-232 Onboard Controller

Stepper, Long Life, 0.2 μ m microstep, RS-232 Onboard Controller

Stepper, Fine Travel, 6.4 μ m fullstep, Direct Mini-DIN 8

Stepper, Long Life, 12.8 μ m fullstep, Direct Mini-DIN 8

Yaw Actuator

Manual Micrometer (default)

*A micrometer where the smallest division is 30 arc sec
(15 arc min per revolution)*

Stepper, Fine Travel, 0.1 μ m microstep, RS-232 Onboard Controller

Stepper, Long Life, 0.2 μ m microstep, RS-232 Onboard Controller

Stepper, Fine Travel, 6.4 μ m fullstep, Direct Mini-DIN 8

Stepper, Long Life, 12.8 μ m fullstep, Direct Mini-DIN 8

Pitch Actuator

Manual Micrometer (default)

*A micrometer where the smallest division is 30 arc sec
(15 arc min per revolution)*

Stepper, Fine Travel, 0.1 μ m microstep, RS-232 Onboard Controller

Stepper, Long Life, 0.2 μ m microstep, RS-232 Onboard Controller

Stepper, Fine Travel, 6.4 μ m fullstep, Direct Mini-DIN 8

Stepper, Long Life, 12.8 μ m fullstep, Direct Mini-DIN 8

Dimensional Drawings

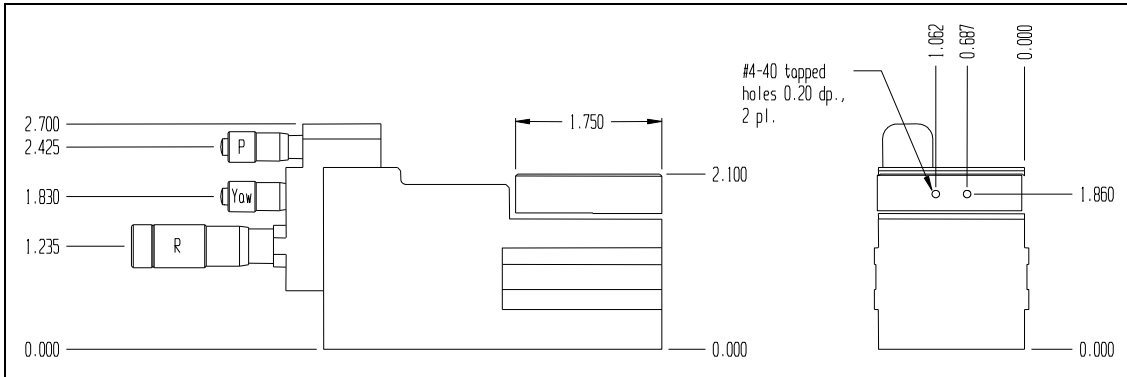

Figure 4 – RYP3000 Positioner (manual) Dimensions - Front & End

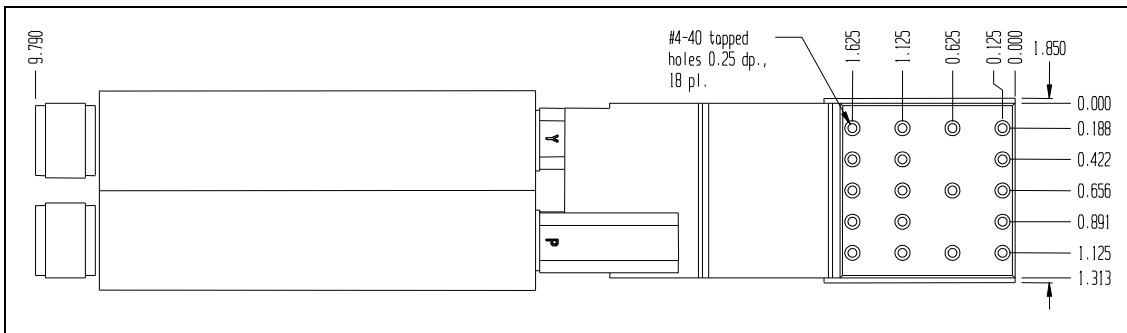

Figure 5 – RYP3000 Positioner (stepper motor) Dimensions - Top

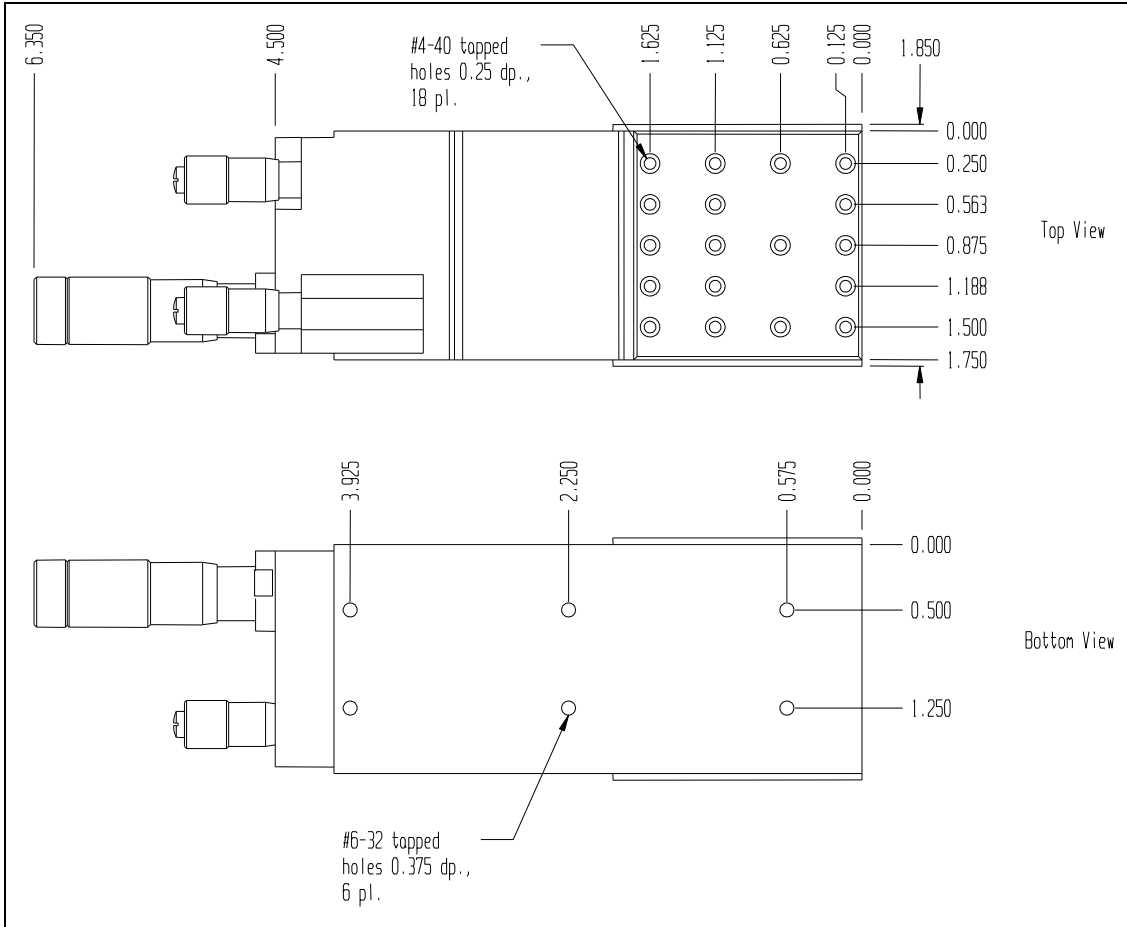

Figure 6 – RYP3000 Positioner (manual) Dimensions - Top & Bottom

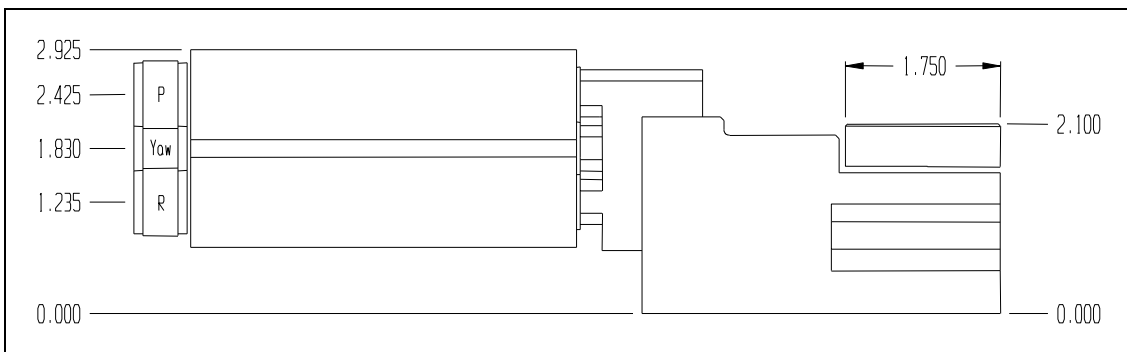

Figure 7 – RYP3000 Positioner (stepper motor) Dimensions - Front

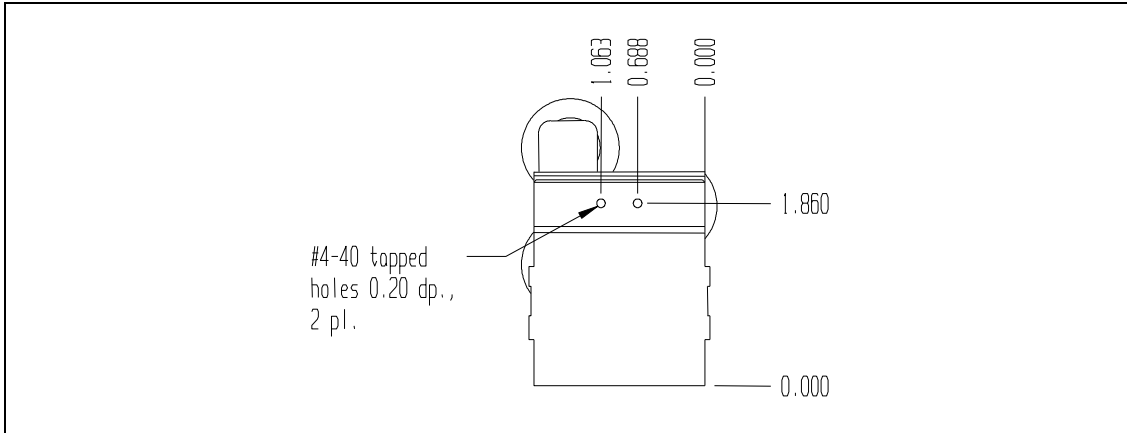

Figure 8 – RYP3000 Positioner (stepper motor) Dimensions - End

Unpacking and Transportation

Do not discard packaging! The warranty is void if a Positioner is not shipped in the original packaging

Warranty

All items manufactured by Luminos Photonics are warranted to meet Luminos Photonics published specifications and to be free of defects in materials and workmanship as defined in the specifications for 90 days after delivery. Luminos Photonics will, at its own option, repair or replace without charge any listed item discovered to be defective.

Luminos Photonics will not be held liable for any loss whatsoever beyond the purchase price paid by the buyer for the goods to which claim is made. Luminos Photonics does not give implied warranties of merchantability, fitness for a particular purpose, or of any other nature in connection with the sale of any Luminos Photonics products.

Products not returned in original packaging will void this warranty.

This warranty does not extend to cover damage resulting from alteration, misuse, negligence, abuse, normal wear and tear, or accident.

Contact Us

Thank you for purchasing a Luminos product. We want to ensure your experience is a positive one. If you have any questions, concerns, or comments do not hesitate to contact us.

Mailing Address

Luminos Photonics
100-159 Cleopatra Drive
Ottawa, Ontario
K2G 5X4 - Canada

Business Hours

Monday to Friday: 9:00am-4:30pm EST

Phone Contacts

Telephone: 1 (613) 225-7661
Fax: 1 (613) 225-3391

Email Contacts

Sales: sales@luminos.com
General Inquiry: info@luminos.com
Support: support@luminos.com

