

NOTE: Stage is shown in mid-position of travel
Z-Axis travel: +/- 0.250" (6.35mm)

LUMINDS INDUSTRIES LTD

I1000 Single Axis Positioner (manual) - Outline (Entire Stage)

Material:
Finish: Tolerance

SIZE A	VIEW	DWG. NO.	I1000-01	REV
SCALE 0.75	FILE: I1000.prt	SHEET	1/2	PAGE

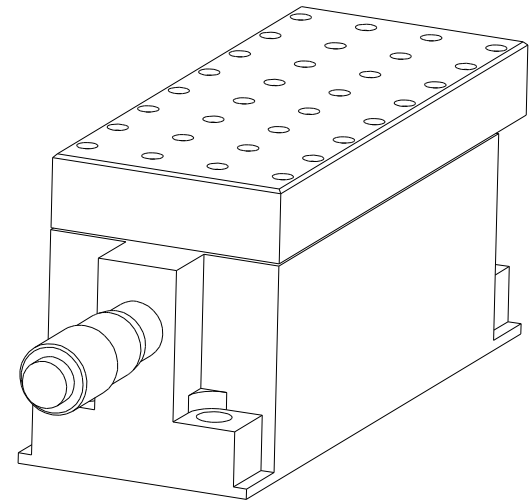
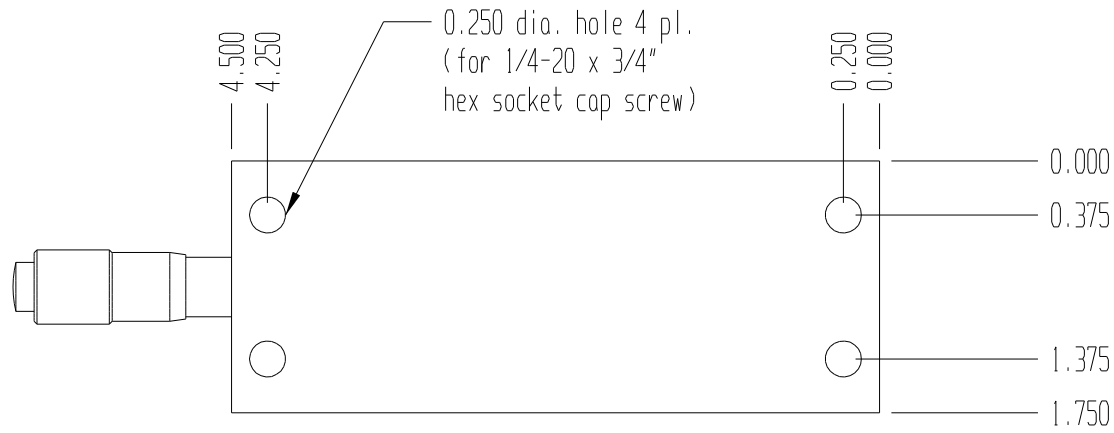

LUMINOS INDUSTRIES LTD			
I1000 Single Axis Positioner - Bottom Outline + Perspective View			
SIZE A	VIEW	DWG. NO. I1000-01	REV
SCALE 0.75	FILE: I1000.prt	SHEET 2/2	PAGE

Material:	
Finish:	Tolerance

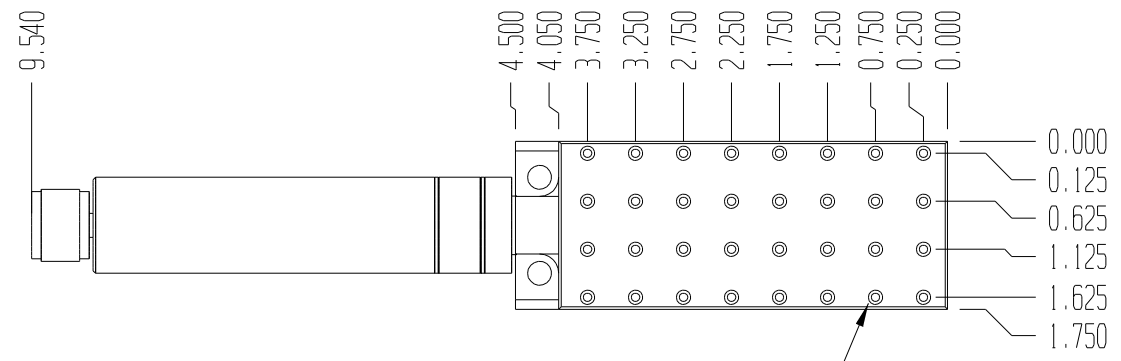

4-40 tapped holes 0.30 dp., 32 pl.

#4-40 tapped hole 0.25 dp., 6 pl.

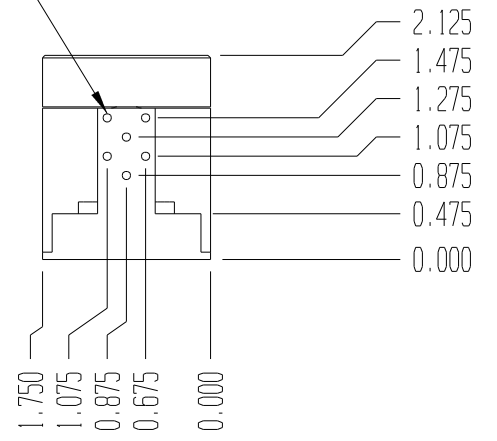
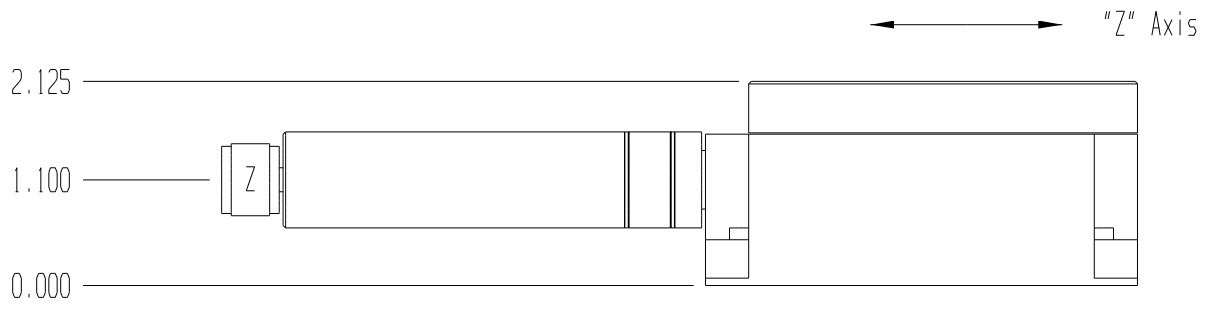

NOTE: Stage is shown in mid-position of travel
Z-Axis travel: +/- 0.250" (6.35mm)

LUMINDS INDUSTRIES LTD			
I1000 Single Axis Positioner (stepper motor) - Outline			
SIZE A	VIEW	DWG. NO.	I1000-02
SCALE 0.5	FILE: I1000.prt	SHEET	1/2
		PAGE	

Material:	
Finish:	Tolerance

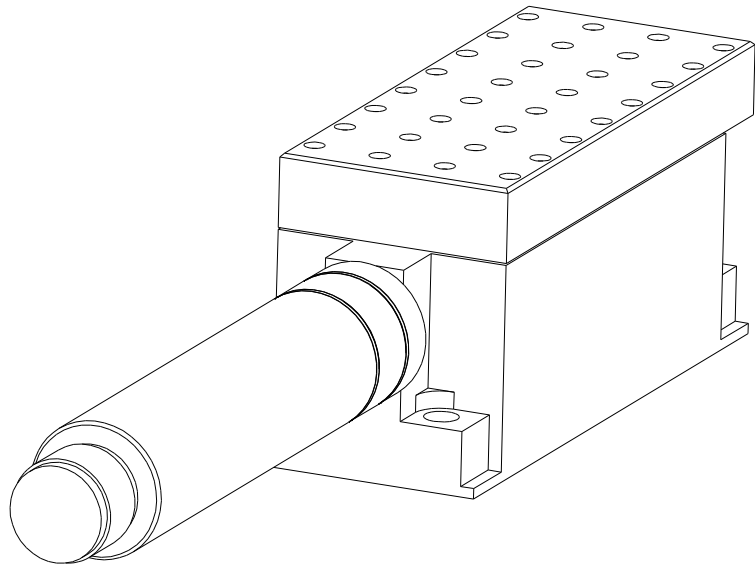
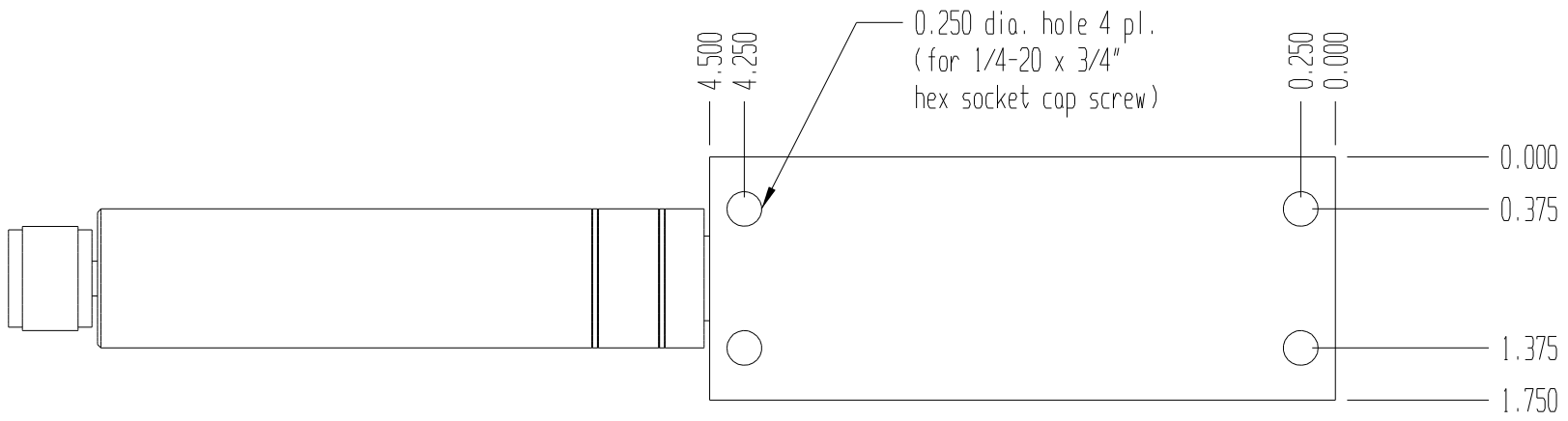

LUMINDS INDUSTRIES LTD

I1000 Single Axis Positioner (Stepper Motor)
Bottom Outline + Perspective View

Material:
Finish: Tolerance

SIZE A	VIEW	DWG. NO. I1000-02	REV
SCALE 0.75	FILE: I1000.prt	SHEET 2/2	PAGE